

H501SAJ200 BOOST/VAC KIT

PART NUMBER	ISSUE	DATE	SUBARU OF AMERICA	PAGE
H501SAJ200	1	6/18/09		16 of 16

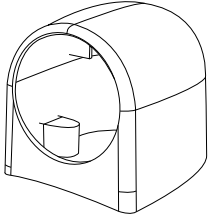
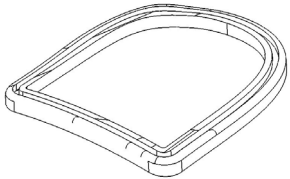
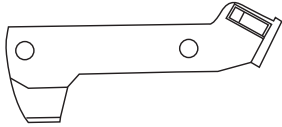
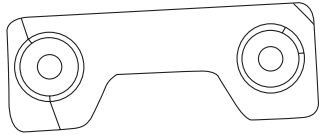
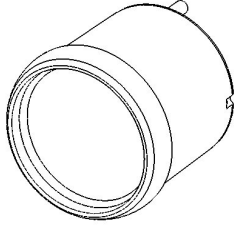
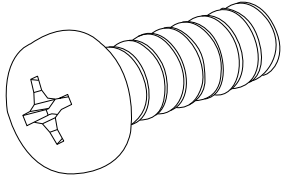
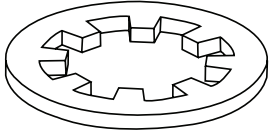
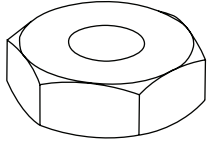

2650-1448-77rC

PART NUMBER	ISSUE	DATE	SUBARU OF AMERICA	PAGE
H501SAJ200	1	6/18/09		1 of 16

KIT CONTENTS				
A	1x	B	1x	
Mounting Pod 		Pod Gasket 		
C	1x	D	1x	
Gauge Bracket 		Backing Plate 		
E	1x	F	2x	
Gauge 		Pod Mounting Screw 		
G	2x	H	2x	
Gauge Mounting Washer 		Gauge Mounting Nut 		
PART NUMBER	ISSUE	DATE	SUBARU OF AMERICA	PAGE
H501SAJ200	1	6/18/09		2 of 16

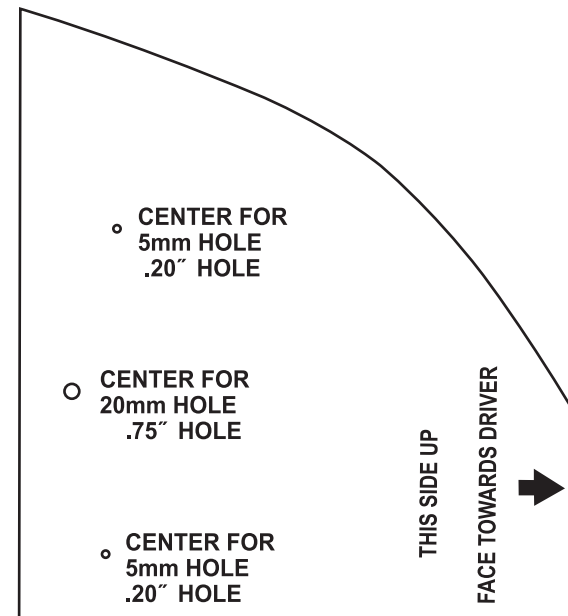
Cutting Template

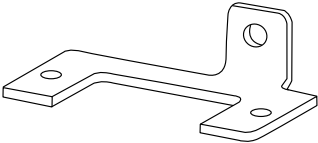
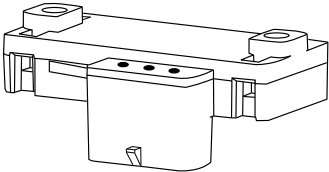
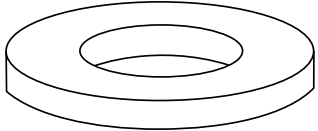
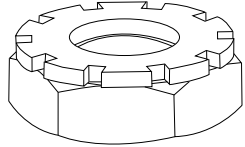
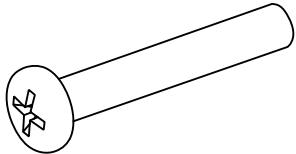
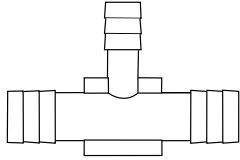
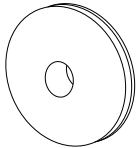
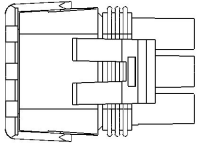
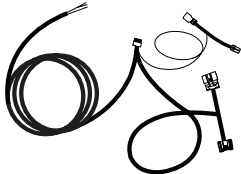
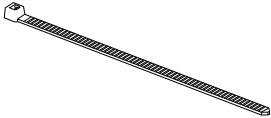
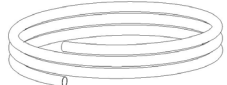





I	1x	J	1x
MAP Sensor Mounting Bracket 		MAP Sensor 	
K	2x	L	2x
MAP Sensor Mounting Washer 		MAP Sensor Mounting Nut 	
M	2x	N	1x
MAP Sensor Mounting Screw 		T-Fitting 	
O	1x	P	1x
Grommet 		MAP Sensor Connector 	Wiring Harness 
R	5x	S	1x
Cable Tie 		Vacuum Tubing 	Sealant 
PART NUMBER	ISSUE	DATE	PAGE
H501SAJ200	1	6/18/09	14 of 16

PART NUMBER	ISSUE	DATE	SUBARU OF AMERICA	PAGE
H501SAJ200	1	6/18/09		14 of 16

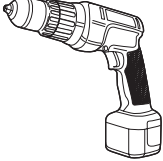
PART NUMBER	ISSUE	DATE	SUBARU OF AMERICA	PAGE
H501SAJ200	1	6/18/09		3 of 16

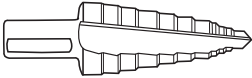
TOOLS REQUIRED

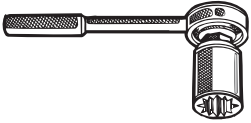
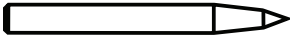
<p>Drill</p> 	<p>#10 or 3/16" or 5mm Drill Bit</p> 
<p>Trim Removal Tool</p> 	<p>Step Drill Bit 14mm-25mm or 0.5-1.0"</p> 
<p>#2 Phillips Screw Driver</p> 	<p>Open end wrench 10mm</p> 
<p>12mm Socket</p> 	<p>Drill Punch</p> 

SAFETY:

INSTALL WHILE ON A LEVEL SURFACE
 SET PARKING BRAKE
 WEAR SAFETY GOGGLES
 PULL IGNITION KEY and DISCONNECT BATTERY

TORQUE SPECIFICATIONS

STEP	DESCRIPTION	Torque
18	Assembly of Gauge Bracket to Gauge	6 in lbs / 0.678 Nm
22	Assembly of the Pod to the dash board	12 in lbs / 1.35 Nm Torque not to exceed 14 in lbs / 1.58 Nm
24	Assembly of the MAP Sensor to the MAP Sensor Bracket	12 in lbs / 1.35 Nm

PART NUMBER	ISSUE	DATE	SUBARU OF AMERICA	PAGE
H501SAJ200	1	6/18/09		4 of 16

31

Tie off vacuum tubing and wire harness as shown.

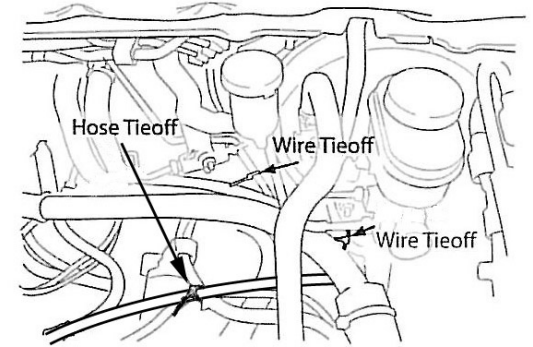

NOTE:

Reassemble the components in the reverse order in which they were disassembled.

PART NUMBER	ISSUE	DATE	SUBARU OF AMERICA	PAGE
H501SAJ200	1	6/18/09		13 of 16

28

Bundle excess MAP sensor wires behind instrument cluster and tie off to dash board frame.

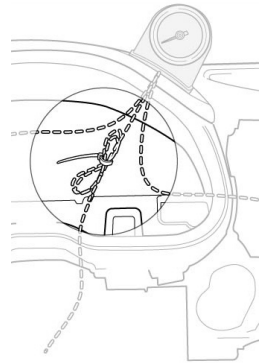

29

Insert the MAP sensor wires to the MAP sensor connector housing as shown.

Connect the MAP sensor connector to the MAP sensor.

Push locking tab on connector housing in place.

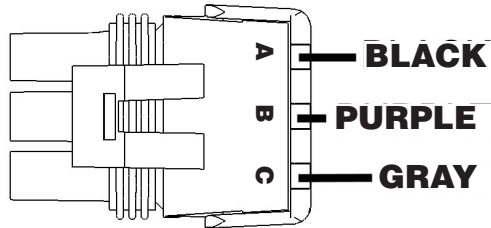

30

Cut the vehicle vacuum tubing and install the T-fitting.

Route the vacuum tubing towards the MAP sensor.

Connect hose to MAP sensor and tie off as shown.

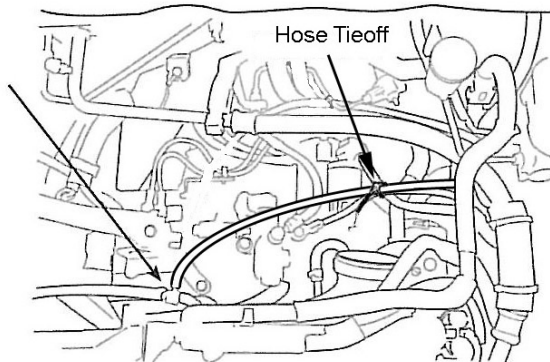

PART NUMBER
H501SAJ200

ISSUE
1

DATE
6/18/09

SUBARU OF AMERICA

PAGE
12 of 16

Passenger Compartment/Center Console

1

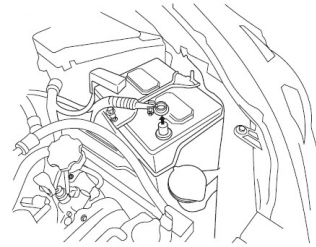

Disconnect the negative battery terminal.

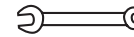

2

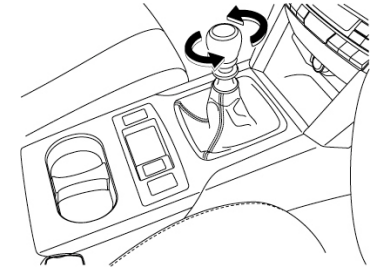

For manual transmission vehicles, twist to remove shift knob.



3

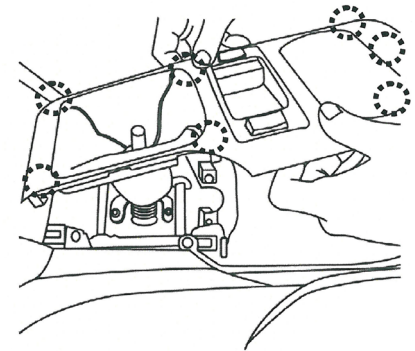

For manual transmission vehicles, remove console trim panel as shown.



4

Remove two screws and then carefully remove side trim panel.

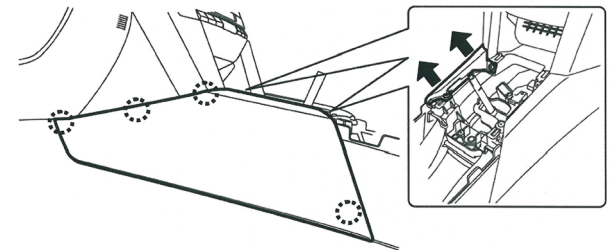

PART NUMBER
H501SAJ200

ISSUE
1

DATE
6/18/09

SUBARU OF AMERICA

PAGE
5 of 16

5

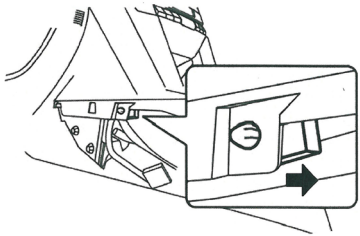

Behind side trim panel, unclip gray antenna connector from vehicle and disconnect.



6

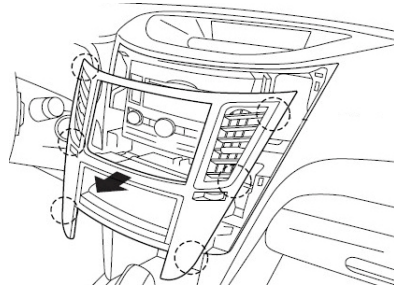

Carefully remove radio trim panel (six clips).



7

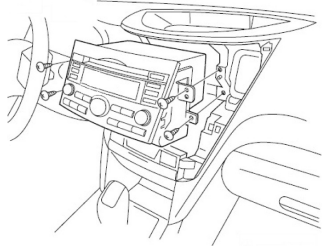

Remove four screws. Remove radio head.



Passenger Compartment/ Instrument Cluster

8

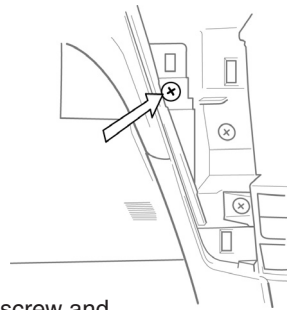

Remove one screw and remove flexible cover, located to the right of the steering wheel.



9

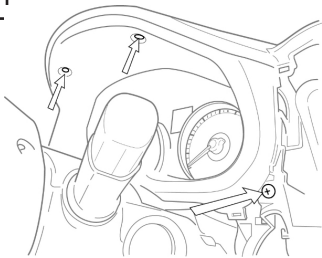

Remove three screws and carefully remove the instrument panel visor.



10

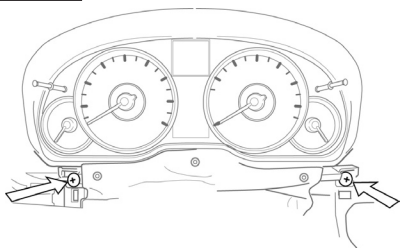

Remove two screws and carefully remove flexible cover from instrument cluster.



25

Remove the top bolt on the bracket that is located on the driver side strut tower.

Put MAP sensor bracket in place, re-insert bolt and tighten.

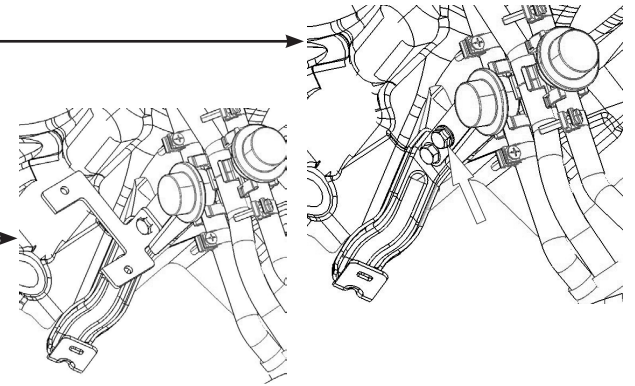
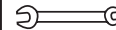

26

Attach the MAP sensor to the MAP sensor bracket.

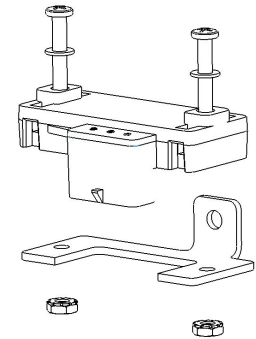
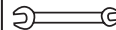

27

Location of the firewall grommet.

1. Remove the harness clip.
2. Remove the OE fire wall grommet.
3. Feed the black, purple and gray wires through the opening in the grommet one wire at a time.
4. Feed wires to the MAP sensor.
5. Install the provided grommet.
6. Place small amount of RTV into grommet/wire gap.

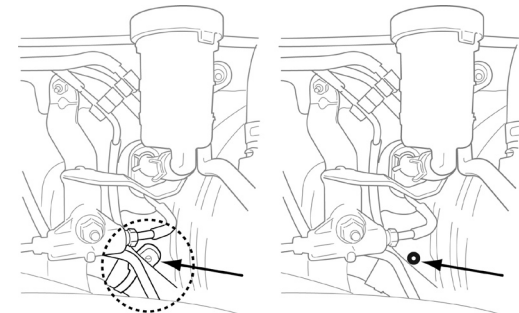

22

Align gauge mounting bracket with pod mounting hole. Tighten mounting screws until there is no gap between the gasket and the dashboard and the screw head and the backing plate. Reassemble the components in the reverse order in which they were disassembled.

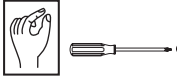
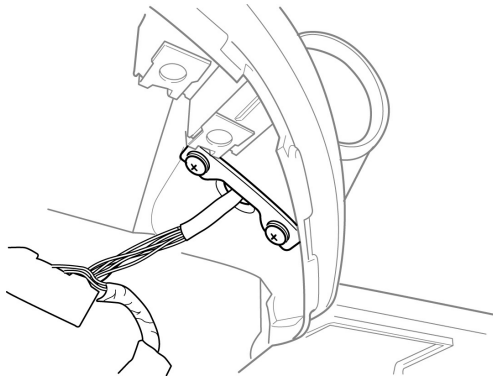

Engine Bay

23

Remove four screws, then remove engine cover.

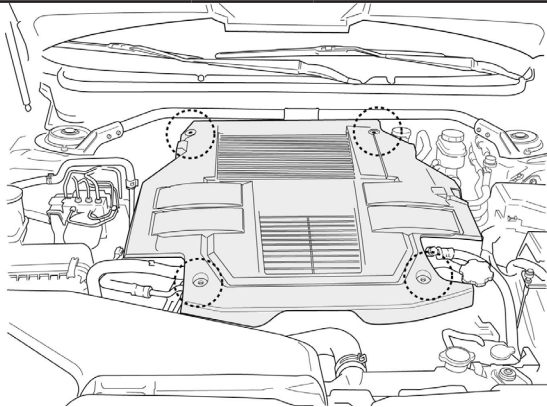

24

Remove intercooler.

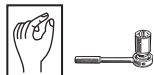
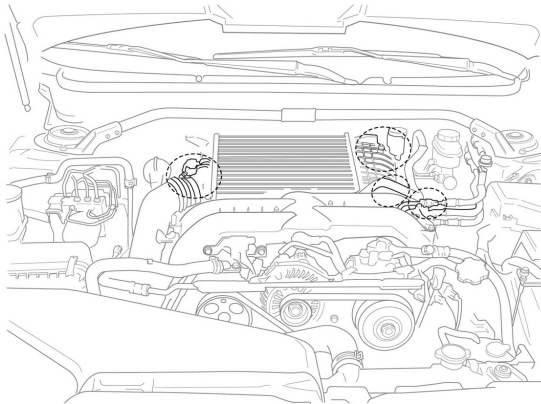

11

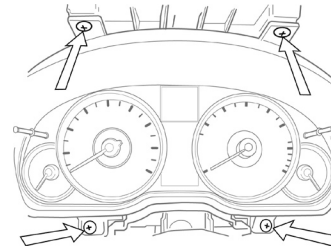

Remove four screws and carefully remove instrument cluster.

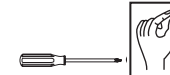

12

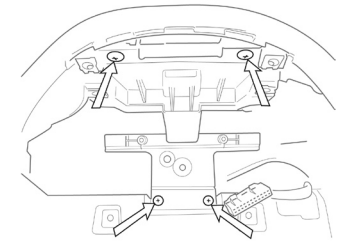

Remove four screws and carefully remove bracket inside of the dash board.

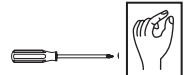

13

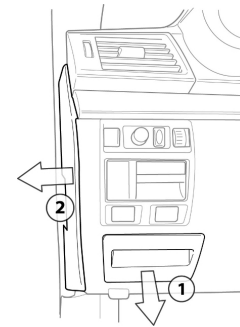

Remove fuse box cover and side panel cover.

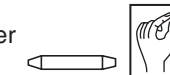

14

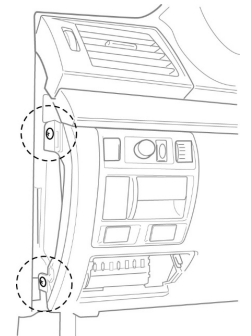

Remove two screws and pull lower instrument panel forward.



15

Disconnect dimmer switch.

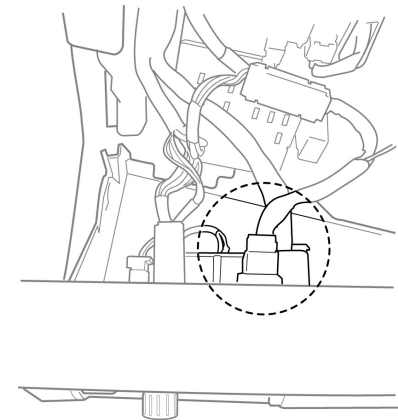

Pod Gauge Assembly

16

1. Place cutting template (see back cover) on dash board.
2. Align left edge of the template with the crease on the dash as shown.
3. Align the right point of the template with the edge of the top surface of the dashboard as shown.
4. Drill two 5mm (.20") holes for pod mounting screws.
5. Using a step drill, drill one 20mm (.75") hole for 10 pin gauge connector.

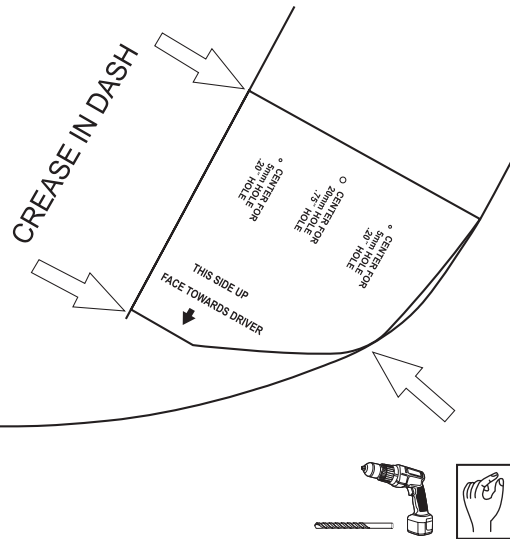

17

1. Feed the two 6 pin connectors behind the opening of the instrument cluster towards the dimmer switch on the left side of the dash board.
2. Connect the two 6 pin connectors at the dimmer switch. Female to switch. Male to vehicle harness.
3. Feed the two 20 pin connectors into the opening for the radio unit in the center console. Connect the two 20 pin connectors. Male to vehicle harness.
4. Feed the 10 pin connector from under the dash board through the 20mm opening in the dash.
5. Route the black, purple and gray wires towards the driver's side foot well. (DO NOT ASSEMBLE THEM TO THE MAP SENSOR CONNECTOR HOUSING AT THIS TIME.)
6. Use wire ties to ensure that the harness stays out of the way of the accelerator, brake and clutch assembly.

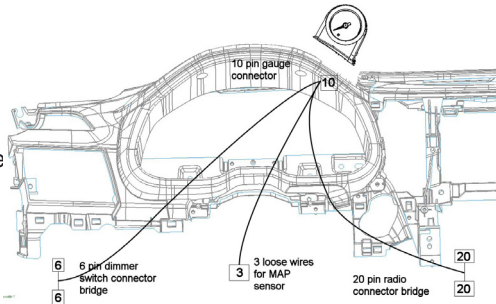

18

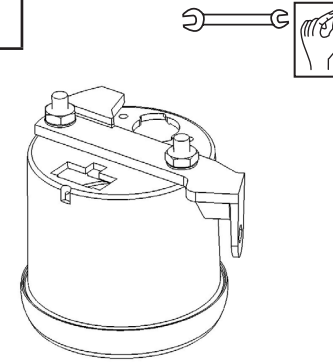

Attach bracket to gauge.
Put two star washers and two nuts on studs. Tighten nuts.

19

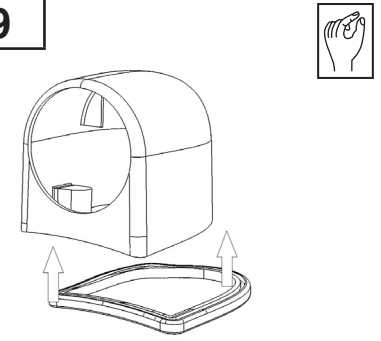

Feed the 10 pin connector through the 20mm opening in the dash, the gasket and through the pod. Attach the gasket to the pod.

20

Insert gauge and bracket into pod and rotate into position.

NOTE: The hole in the bracket is aligned with the hole in the boss inside the pod.

Attach the 10 pin connector to the gauge.

The harness is not shown in this picture.

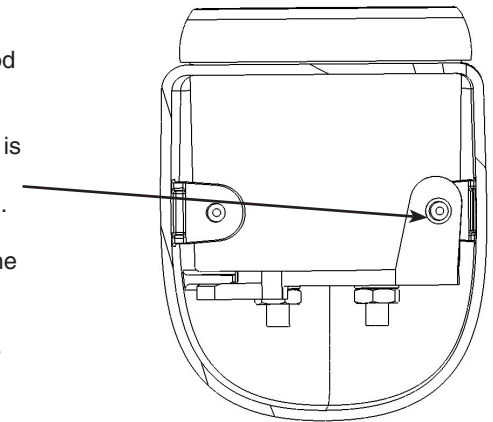

21

Place pod/gauge/gasket on the dash.

