

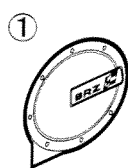

PART No. J1210CA800

BRZ Fuel Lid Garnish
 Garnissez le couvercle de carburant
 Kraftstoff Deckel Garnitur
 Carburante coperchio guarnire
 Combustible adornar la tapa
 Гарнир топлива крышкой

Installation Instruction
 Guide D' Installation
 Einbauanleitung
 Manuale D' Installazione
 Manual De Instalacion
 Инструкция по установке



①
 x1



②
 x1

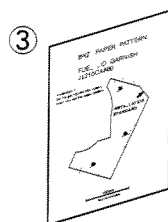

③
 x1



(Trash Can)

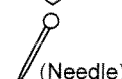
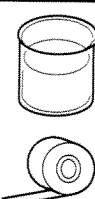

(Needle)

NOTE:

- Do not wash the vehicle for 24 hours following installation of this product.
- If this product requires cleaning after installation, wipe with a soft cloth or sponge with mild detergent and wipe thoroughly with a dry cloth. Do not use gasoline, thinner, acid, alkaline or other solvent based products.
- The recommended adhesive surface temperature range is 77°F - 104°F (25°C - 40°C).
- If the surface temperature is below 60°F (15°C), heat the double sided tape and Fuel Lid around to a temperature of 77°F - 104°F (25°C - 40°C).

REMARQUE:

- Ne nettoyez pas le véhicule pendant 24 heures après la repose de ce produit.
- Si ce produit requiert un nettoyage après la repose, utilisez un tissu doux ou une éponge avec du détergent doux, puis un tissu sec. N'utilisez pas d'essence, de diluant de solvant acide, alcalin ou tout autre produit à base de solvant.
- La température de surface adhésive recommandée est comprise entre 77°F et 104°F (25°C et 40°C).
- Si la température de surface adhésive recommandée est inférieure à 60°F (15°C), chauffez le ruban adhésif double-face et la Autour du couvercle de carburant à une température de 77°F et 104°F (25°C et 40°C).

HINWEIS:

- Fahrzeug für 24 Stunden nach der Installation dieses Produkts nicht waschen.
- Wenn dieses Produkt nach der Installation gereinigt werden muss, mit einem weichen Tuch oder Schwamm und einem milden Reinigungsmittel einreiben und mit einem trockenen Tuch gründlich abwischen. Verwenden Sie kein Benzin, Verdünner, Säuren, Laugen oder andere Produkte mit Lösungsmitteln.
- Der empfohlene Klebstoff Oberfläche temperaturbereich liegt zwischen 77°F (25°C) und 104°F (40°C).
- Liegt die Klebstoff Oberflächentemperatur unter 60°F (15°C), doppelseitiges Klebeband und Rund um den Kraftstoff-Deckel auf eine Temperatur von 77°F (25°C) und 104°F (40°C) erwärmen.

NOTA:

- Non lavare il veicolo per 24 ore dopo installazione di questo prodotto.
- Se questo prodotto necessita di pulizia dopo installazione, utilizzare un panno morbido o una spugna con un detergente neutro e asciugare accuratamente con un panno asciutto. Non utilizzare benzina, solventi, acidi, alcalini o altri prodotti a base di solvente.
- La gamma di temperatura raccomandata per la superficie adesiva è di 77°F - 104°F (25°C - 40°C).
- Se la temperatura della superficie è inferiore a 60°F (15°C), riscaldare il nastro biadesivo e la Intorno al coperchio carburante ad una temperatura di 77°F - 104°F (25°C - 40°C).

NOTA:

- No lave el vehiculo durante las 24 horas posteriores a la instalación de este producto.
- Si este producto requiere limpieza después de la instalación, lave con un paño delicado o una esponja con detergente suave y limpie cuidadosamente con un paño seco. No utilice gasolina, diluyente, ácido, productos alcalinos u otros productos disolventes.
- El rango de temperatura recomendado de la superficie del adhesivo es 77°F - 104°F (25°C - 40°C).
- Si la temperatura de la superficie es inferior a 60°F (15°C), caliente la cinta de doble cara y la Alrededor de la tapa de combustible hasta una temperatura de 77°F - 104°F (25°C - 40°C).

ПРИМЕЧАНИЕ:

- После установки данного изделия не мойте автомобиль в течение 24 часов.
- Если после установки данное изделие нуждается в чистке, протрите его мягкой тканью или мочалкой с использованием мягкодействующего моющего средства и тщательный вытрите сухой тканью. Не используйте бензин, растворитель, кислоту, щелочь или другие продукты, содержащие растворители.
- Рекомендованная температура поверхности приклеивания составляет 77°F-104°F (25-40°C).
- Если температура поверхности составляет менее 60°F (15°C), нагрейте двусторонний ленту и Вокруг топлива крышкой до температуры 77°F-104°F (25-40°C).

1

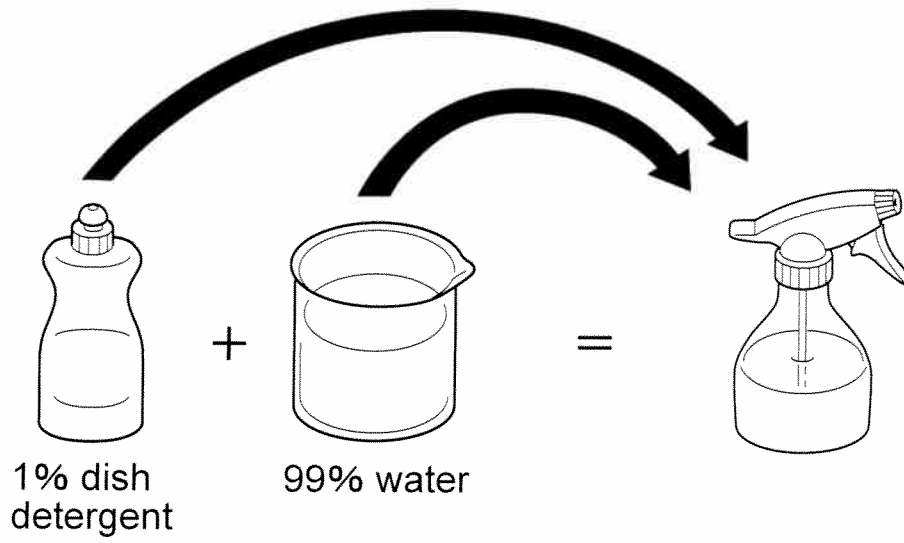

2

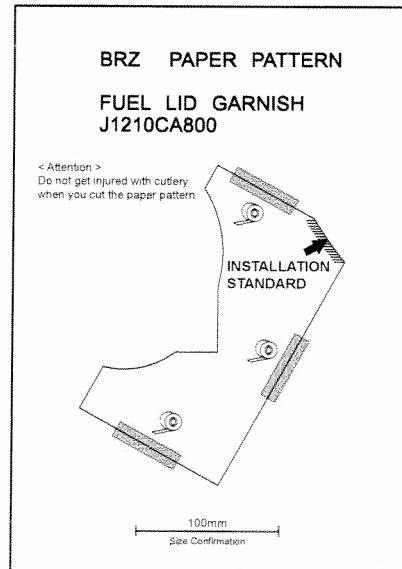
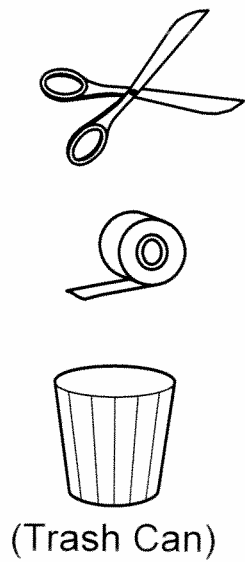

3

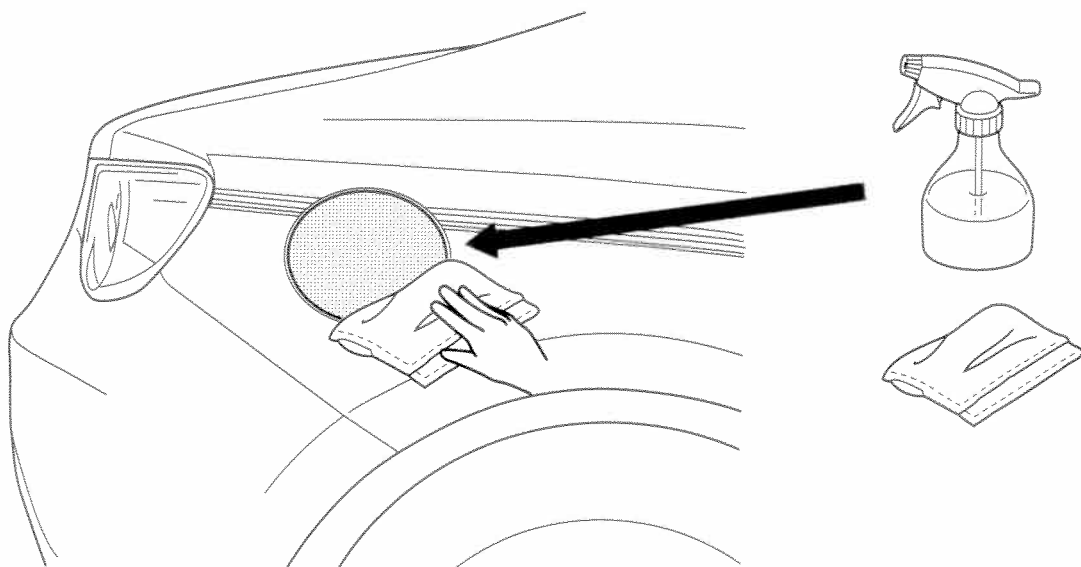

4

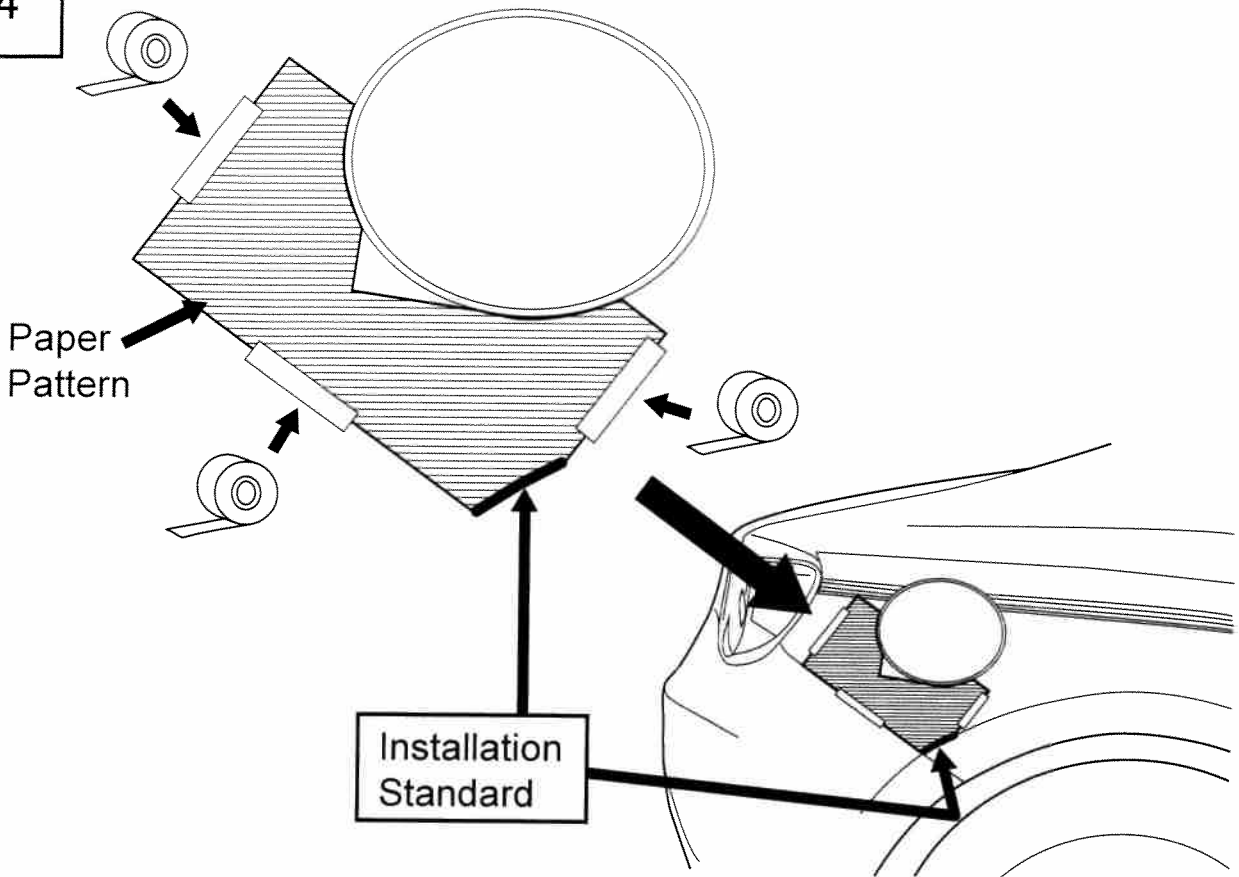

5

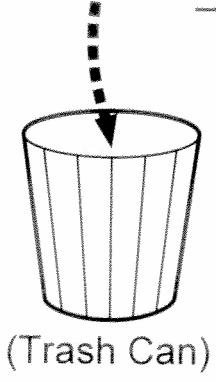
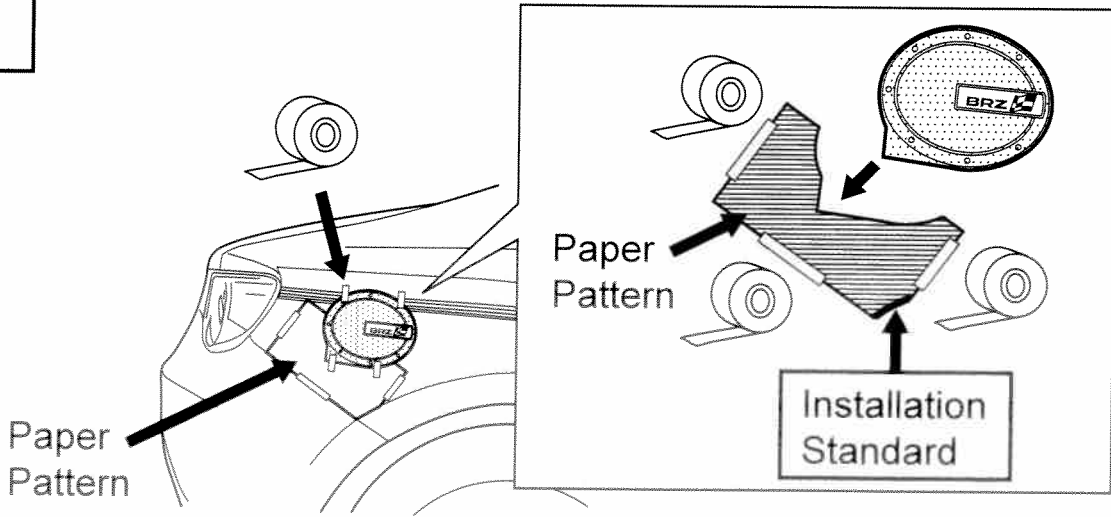

Check alignment of
Fuel Lid Garnish with
Fuel Lid.

Adjust Paper Pattern
as needed.

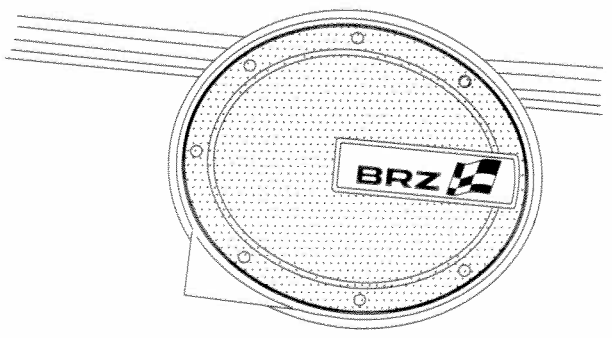

6

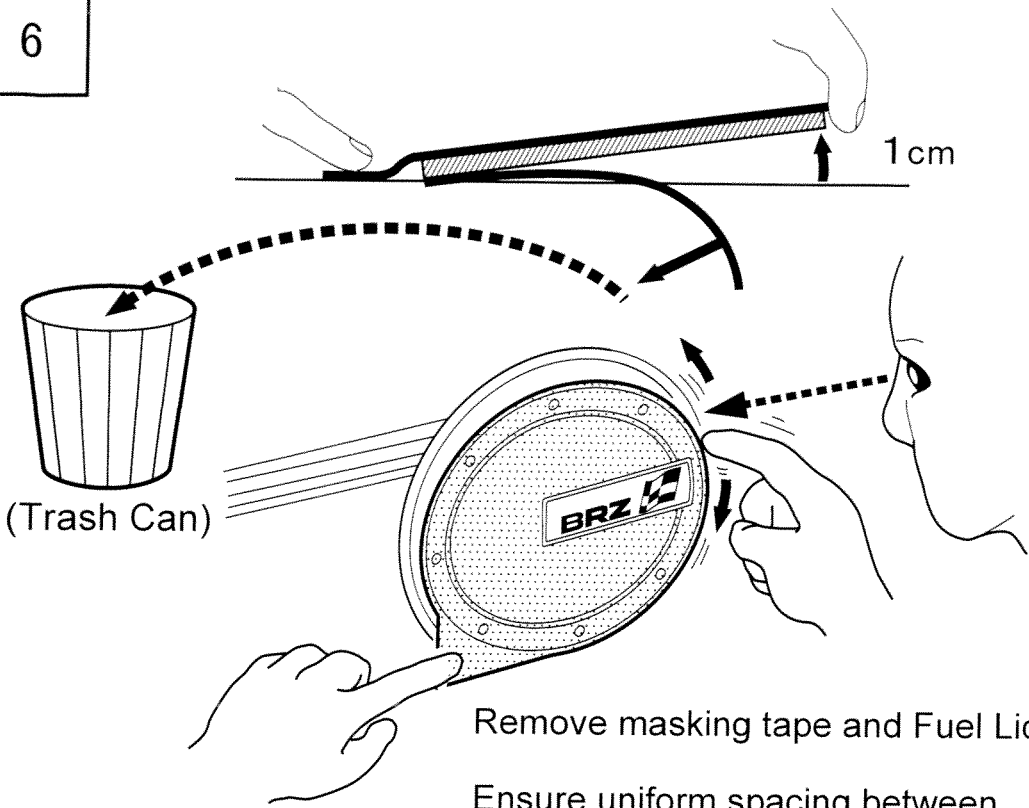

Remove masking tape and Fuel Lid Garnish backing.

Ensure uniform spacing between edge of Fuel Lid Garnish and Fuel Lid while installing Fuel Lid Garnish.

7

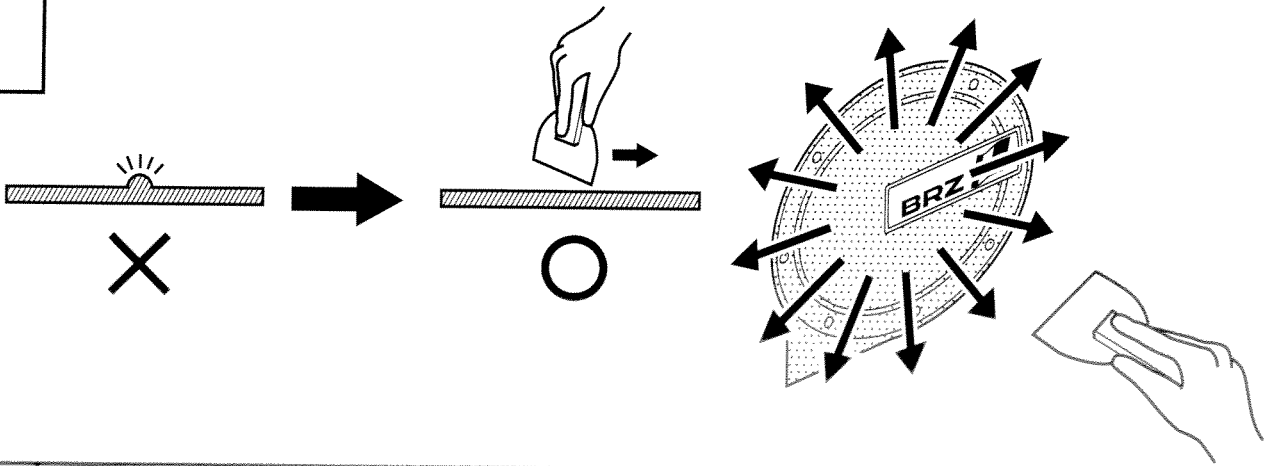

8

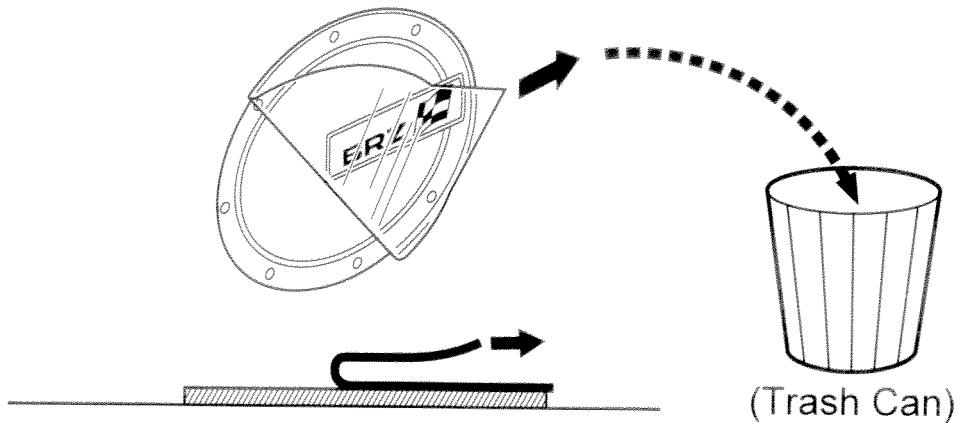

9

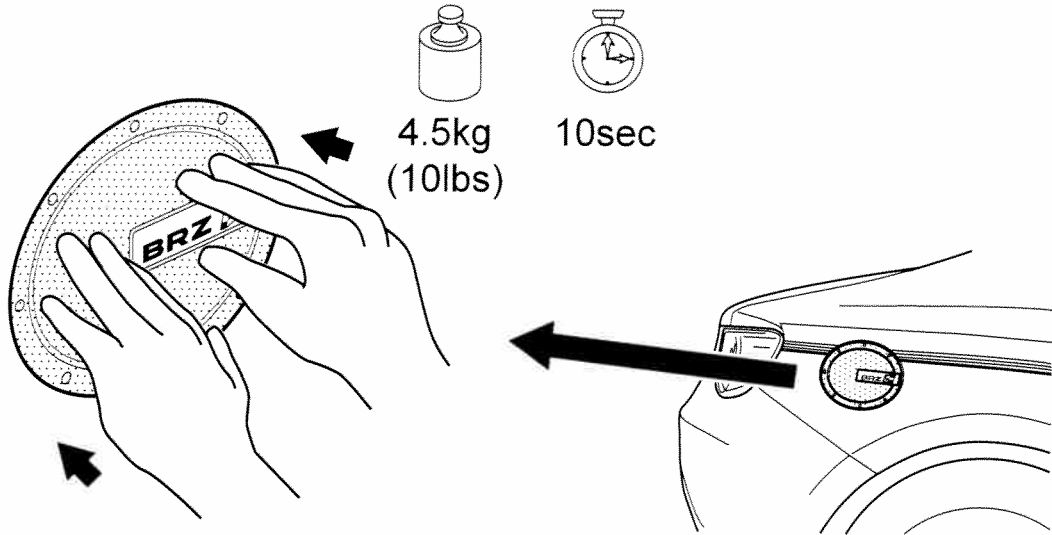

10

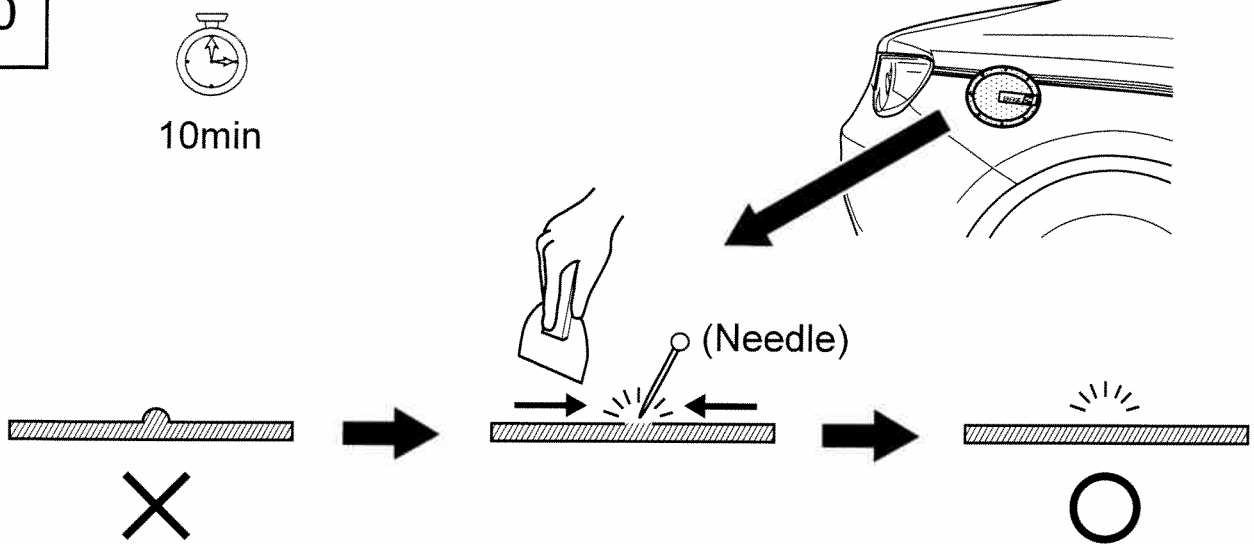

11

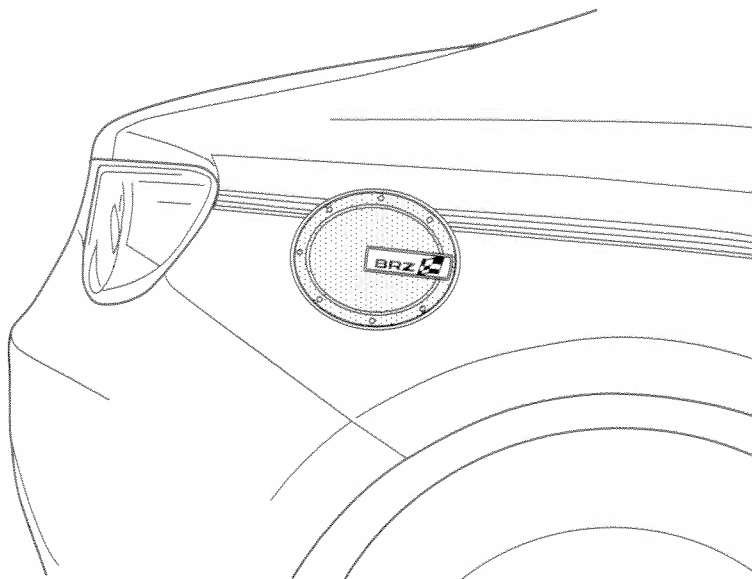

BRZ PAPER PATTERN

FUEL LID GARNISH J1210CA800

< Attention >

Do not get injured with cutlery
when you cut the paper pattern.

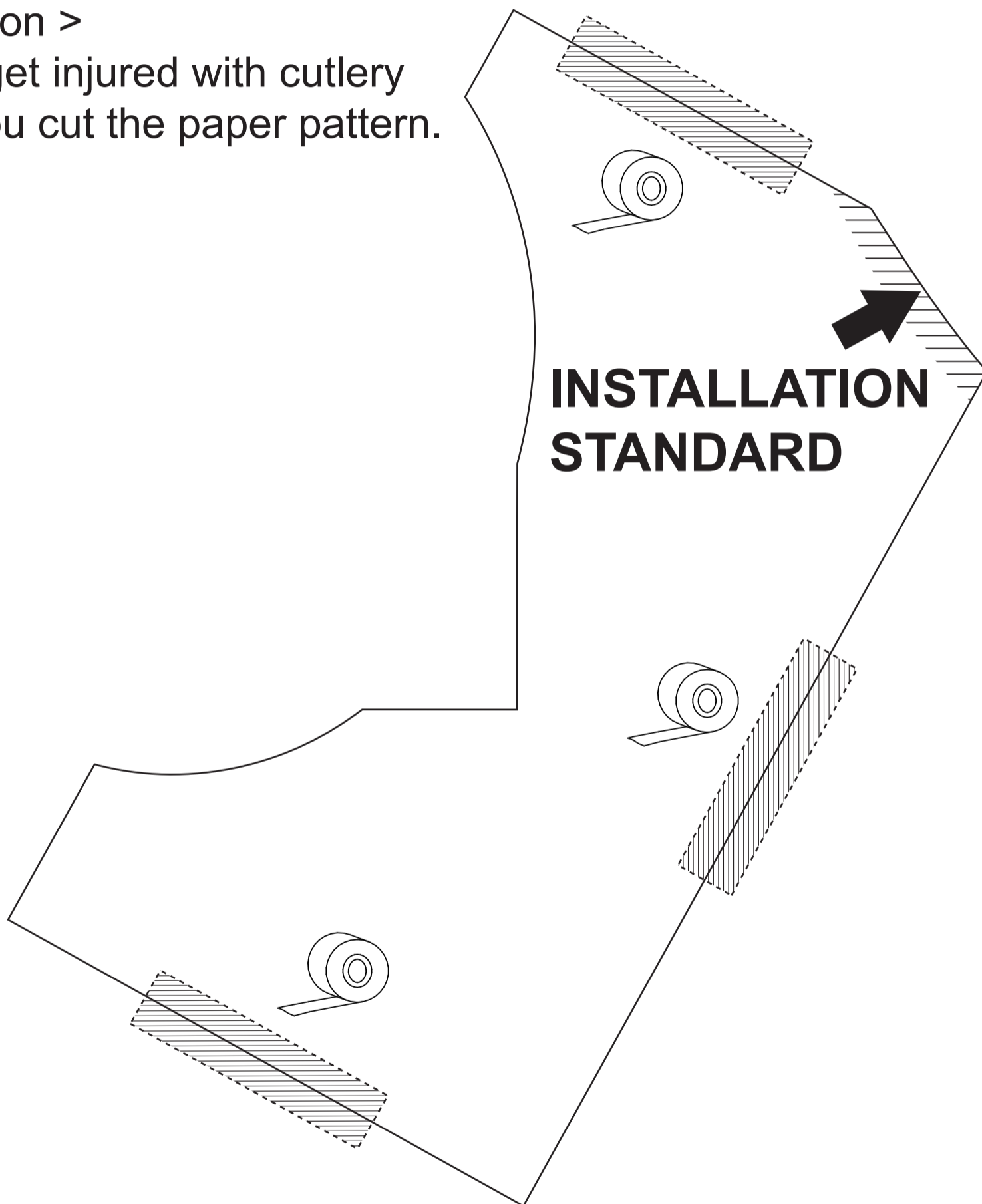

100mm
Size Confirmation